

What is JTAG?

JTAG, also commonly known in the industry as Boundary Scan. The JTAG is a solution to control devices from inside, using a simple 4-wire interface to the device known as a TAP.

Boundary Scan (or JTAG) has existed for over a decade and is already implemented in most FBGAs, CPLDs, DSPs, μ Ps, etc. However, its potential as a testing and programming tool is only just beginning to be fully realised.

Connection testing and In System Programming (ISP) are the two applications most commonly associated with boundary scan, but with recent development in this technology it now has far more to offer in not only being able to test boundary scan compliant devices but also non-boundary scan devices.

I/O Board Increased Test Coverage

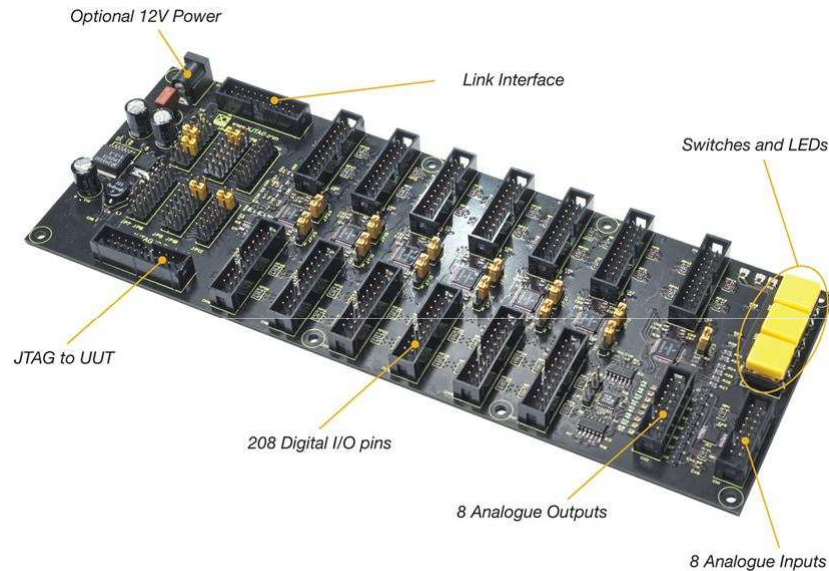

The I/O board is an expansion unit that will integrate with the JTAG Test system to allow test verification of non-JTAG compliant components.

With a range of Digital and Analogue I/Os on the I/O board, we can increase test coverage and improve fault isolation down to the faulty signal pin on your DUT.

I/O Board Increased Test Coverage Cont

Now we can test more components for internal open or shorts by connecting signals from your Device Under Test (DUT) to the JTAG I/O board.

The JTAG system can drive signals through our custom made test fixtures into the DUT and identify the nature of the fault within the device down to pin level. On JTAG compliant devices we can determine whether the fault lies within the Silicon or within the wire bounding.

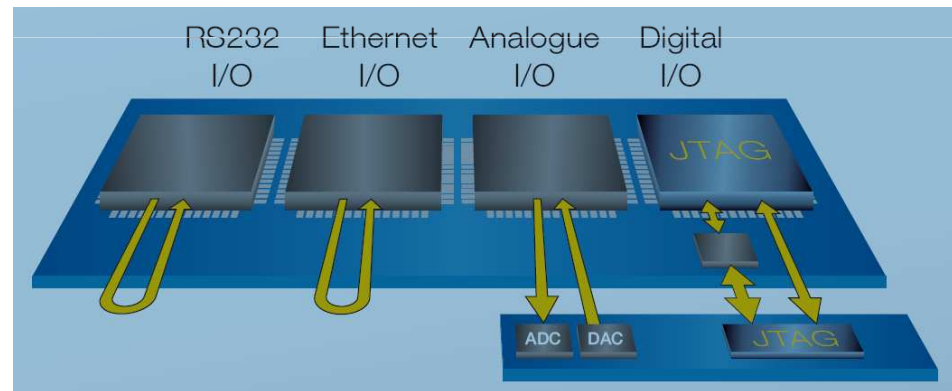

With on-board DAC and ADC the I/O interface board provides a mechanism for analogue as well as Digital testing.

Using this functionality, even components with no JTAG TAP access can be "BLACKBOX" tested.

Digital Interface

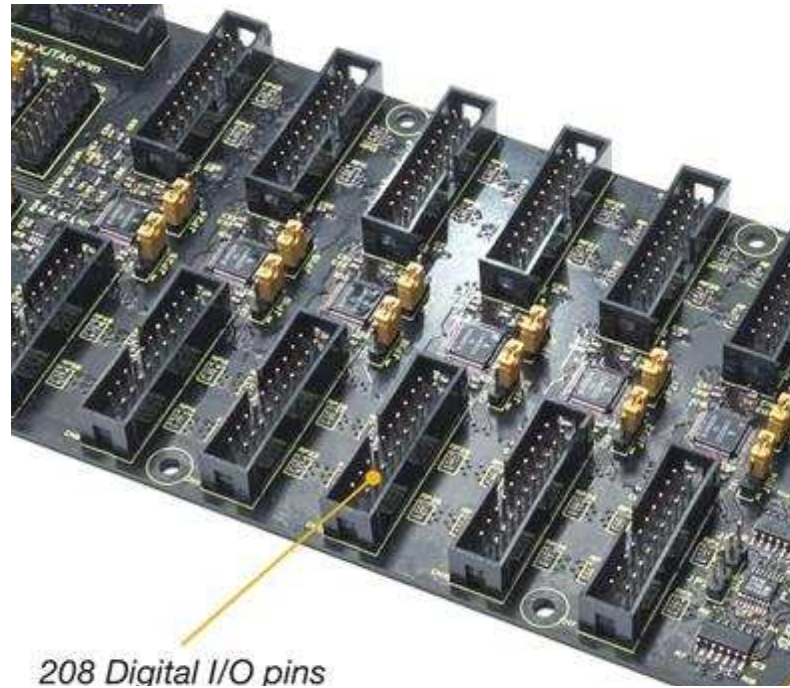

With the 208vbi-directional digital I/O pins, the I/O board has been designed for maximum connectivity. The I/O pins are all 5volts tolerant. The default logic level is 3.3volts, or we can re-configure the I/O pins, in Block of 16, to use any user defined voltage between 3.3volts and 1.8volts

Analogue Interface

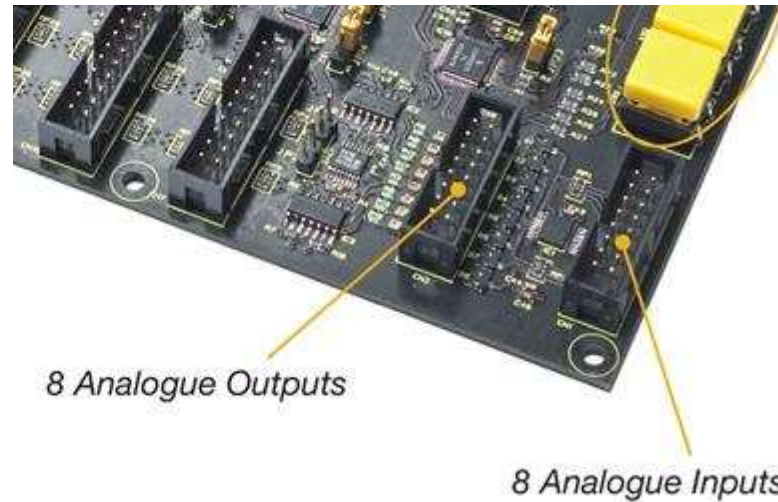

The I/O JTAG board has 8 analogue inputs and 8 analogue outputs, controllable via the JTAG interface. The on-board ADC enables analogue measurements – e.g. testing a power rail is within limits. The DAC allows analogue inputs on the DUT to be stimulated, improving test coverage of the target Device.